



Design Features include:

- Long life with alloy steel tapered grids
- Extended maintenance periods with the use of Falk Long Term Grease
- Easy maintenance with the replace-in-place design
- Absorbs shock loads and offers vibration damping with the original Falk Steelflex T-Grid design

Applications:

- Paper machines
- Ball mills
- Hot bed rolls
- Slurry pumps
- Conveyors
- Blowers and fans
- Centrifugal pumps

Industry Compliant:

- ATEX II 2GD c T6

Special design options:

- Type T63 disc brake
- Type T90 flywheel
- Type BW brake wheel
- In total 12 models to choose from

Rexnord Falk Steelflex Grid Coupling

Customer-focused solutions. Reliable Performance. Trusted Brands.

You want a trusted name when it comes to providing engineered power transmission products that improve productivity and efficiency. Rexnord® provides superior products for your industrial applications world wide. We work closely with you to reduce maintenance costs, eliminate redundant inventories and prevent equipment downtime.

Falk Steelflex T10 Grid Couplings

The “replace-in-place” design eliminates the need to move hubs or re-align shafts, reducing element change-out time. When lubricated with Falk Long Term Grease (LTG), the low-maintenance Falk Steelflex coupling does not require re-lubrication for five years. The original Falk Steelflex T-Grid design offers superior vibration damping and reduces peak torque loads by as much as 30%, reducing wear on connected equipment components.

Falk is a Rexnord brand.

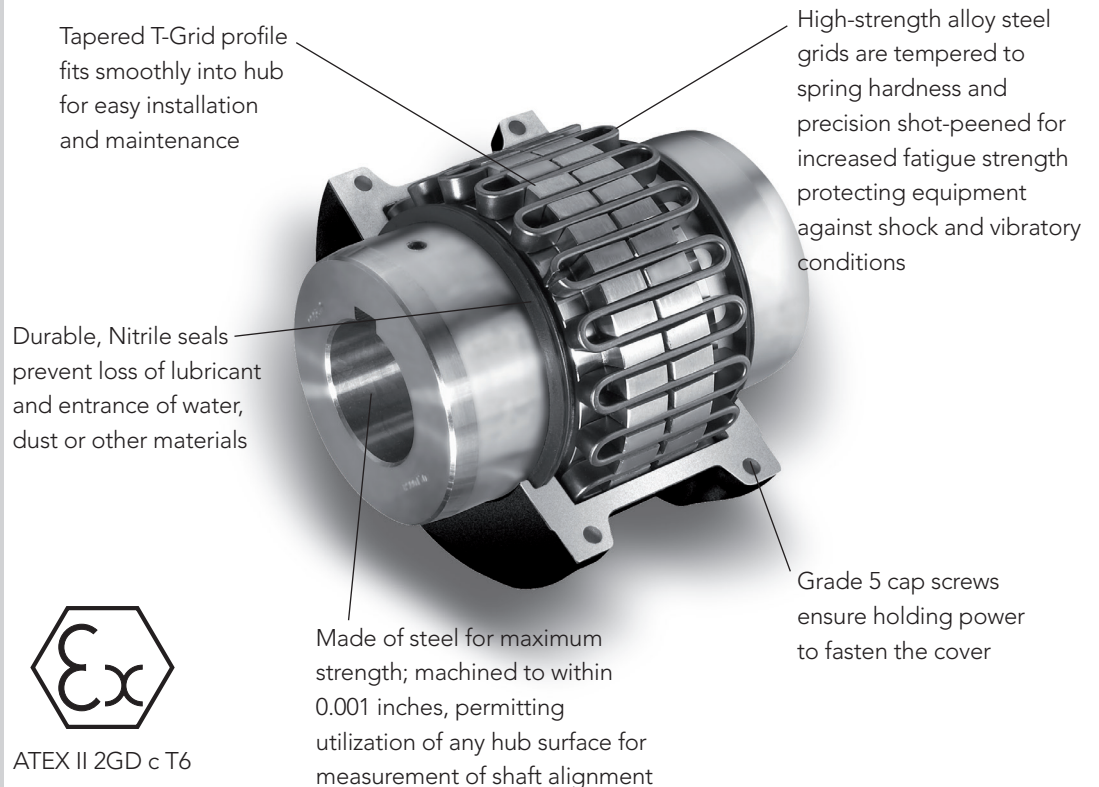

ATEX II 2GD c T6

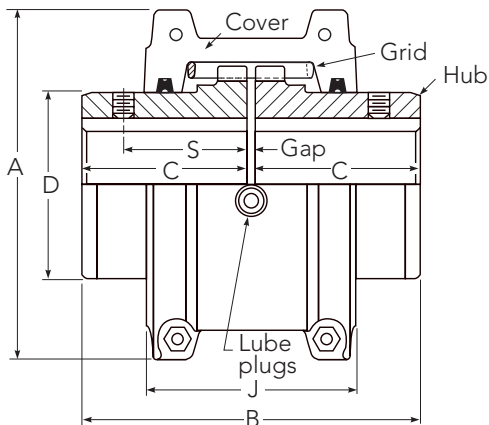

Torque Demands Driven Machine	Typical Application for Electric Motor or Turbine Driven Equipment	Typical Service Factor
	Constant torque such as centrifugal pumps, blowers and compressors	1.0
	Continuous duty with some torque variations including plastic extruders and forced draft fans	1.5
	Light shock loads from metal extruders, cooling towers and log haulers	2.0
	Moderate shock loading as expected from a car dumper, stone crusher, vibrating screen	2.5
	Heavy shock load with some negative torques from reciprocating pumps, compressors, reversing turnout tables	3.0
	Frequent torque reversals such as reciprocating compressors with frequent torque reversals which do not necessarily include reverse rotations	Consult Rexnord Engineering

Coupling Size	Torque Rating	Max. Allowed Speed	Min. Bore	Max. Bore	Gap	A	B	C	D	J	S	Lube Weight	Coupling weight with no bore
	Nm												
1020T	52	4 500	13	28	3	97	98	47	39	66	39,1	0,02	1,9
1030T	149	4 500	13	35	3	105	98	47	49	68	39,1	0,04	2,5
1040T	249	4 500	13	43	3	114	104	50	57	69	40,1	0,05	3,3
1050T	435	4 500	13	50	3	135	123	60	66	80	44,7	0,06	5,4
1060T	684	4 350	20	56	3	147	130	63	76	93	52,3	0,08	7,4
1070T	994	4 125	20	67	3	158	155	76	87	96	53,8	0,1	10,4
1080T	2 050	3 600	27	80	3	190	180	88	104	115	64,5	0,1	17,9
1090T	3 730	3 600	27	95	3	211	199	98	123	122	71,6	0,2	25,6
1100T	6 280	2 440	42	110	5	251	246	120	142	155	0,4	42,0
1110T	9 320	2 250	42	120	5	269	259	127	160	161	0,5	54,3
1120T	13 700	2 025	61	140	6	307	304	149	179	191	0,7	81,2
1130T	19 900	1 800	67	170	6	345	329	161	217	195	0,9	121
1140T	28 600	1 650	67	200	6	384	374	184	254	201	1,1	178
1150T	39 800	1 500	108	215	6	453	371	182	269	271	1,9	234
1160T	55 900	1 350	121	240	6	501	402	198	304	278	2,8	317
1170T	74 600	1 225	134	280	6	566	437	215	355	307	3,4	448
1180T	103 000	1 100	153	300	6	629	483	238	393	321	3,7	619
1190T	137 000	1 050	153	335	6	675	524	259	436	325	4,4	776
1200T	186 000	900	178	360	6	756	564	279	497	355	5,6	1 058
1210T	249 000	820	178	390	13	844	622	304	533	431	10,5	1 424
1220T	336 000	730	203	420	13	920	663	325	571	490	16,1	1 785
1230T	435 000	680	203	450	13	1 003	703	345	609	546	24,0	2 267
1240T	559 000	630	254	480	13	1 087	749	368	647	647	33,8	2 950
1250T	746 000	580	254		13	1 181	815	401	711	698	50,1	3 833
1260T	932 000	540	254		13	1 260	876	431	762	762	67,2	4 682