



Design Features include:

- Replace-in-place design allows quick & easy element replacement without having to move the hubs
- High capacity ratings at a very competitive price
- Polyurethane element has excellent wear and chemical resistance and an operating temperature range of -40°F to 200°F

Applications:

- Pumps
- Compressors
- General Purpose Machinery

Industry Compliant:

- ATEX II 2GD c T5

Rexnord Falk Wrapflex Elastomer Coupling

Customer-focused solutions.

Reliable Performance.

Trusted Brands.

You want a trusted name when it comes to providing engineered power transmission products that improve productivity and efficiency. Rexnord® provides superior products for your industrial applications world wide. We work closely with you to reduce maintenance costs, eliminate redundant inventories and prevent equipment downtime.

Falk Wrapflex®

Low cost elastomer in shear with replace-in-place element. Easy installation and service without need to move hubs or connected equipment.

Falk® is a Rexnord brand.



ATEX II 2GD c T5

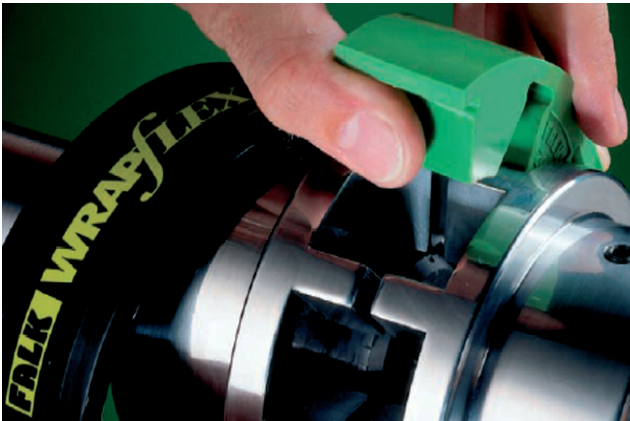

Torque Demands Driven Machine	Typical Application for Electric Motor or Turbine Driven Equipment	Typical Service Factor
	Constant torque such as centrifugal pumps blowers and compressors	1.0
	Continuous duty with some torque variations including plastic extruders and forced draft fans	1.5
	Light shock loads from metal extruders, cooling towers and log haulers	2.0
	Moderate shock loading as expected from a car dumper, stone crusher, vibrating screen	2.5
	Heavy shock load with some negative torques from reciprocating pumps, compressors, reversing turnout tables	3.0
	Frequent torque reversals such as reciprocating compressors with frequent torque reversals which do not necessarily include reverse rotations	Consult Rexnord Engineering

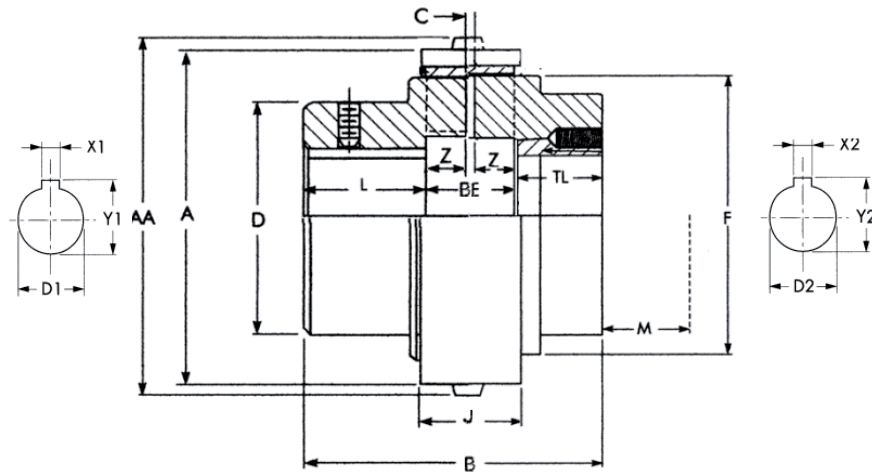

Wrapflex size	T _{nom} Nm	n max min-1	D1		D2		A		AA		B		C	D	L	TL	M	F	Z	m*	
			max. mm	Taper bush mm	max. mm	Nylon mm	Steel mm	Nylon mm	Steel mm	(1) mm	(2) mm	BE mm								BE mm	Nylon kg
5R	62	4 500	38	1108	28	77	77	81	81	72	65	20	2	60	26	23	19	64	9	1,3	1,5
10R	130	4 500	48	1210	32	91	91	95	95	90	90	24	2	72	34	33	27	76	11	2,5	2,7
20R	320	4 500	60	1610	40	126	124	132	130	124	98	32	2	92	45	33	27	102	15	5,6	6,1
30R	520	4 500	65	2012	48	147	143	153	149	152	120	36	2	105	58	42	35	118	17	9,4	10
40R	1 030	3 600	85	2517	60	182	177	190	185	181	139	47	5	130	67	46	42	150	21	17	18
50R	2 500	3 000	105	3020	75	231	224	239	232	215	171	61	5	170	77	55	53	190	28	34	36
60R	4 000	2 500	135	4030	100	-	267	-	278	275	245	75	5	200	100	85	86	228	35	-	62
70R	8 000	2 100	160	4535	110	-	310	-	321	324	264	84	5	227	120	90	104	270	40	-	98
80R	15 000	1 800	190	5040	125	-	370	-	381	376	305	97	6	270	140	104	123	328	45	-	165

*Weight (m) on maximum bore and key way • Dimension B(1), D1 finished bore hubs - B(2), D2 with Taper Bush hubs